

LITTLE WONDER®

PARTS LIST, OPERATING AND
ASSEMBLY INSTRUCTIONS FOR
PRO HONDA POWERED EDGER, MODEL #6232
PRO BRIGGS & STRATTON POWERED EDGER, MODEL #6033



IMPORTANT SAFETY INSTRUCTIONS



To avoid injury when using your Edger, follow basic precautions, including the following:

1. READ THESE IMPORTANT SAFETY INSTRUCTIONS, THE OPERATING INSTRUCTIONS, ASSEMBLY INSTRUCTIONS, USER MAINTENANCE INSTRUCTIONS, AND THE HONDA OPERATING AND MAINTENANCE INSTRUCTIONS CAREFULLY AND COMPLETELY. Be thoroughly familiar with the controls and the proper use of the equipment. Know how to stop the unit and disengage the controls quickly. **SAVE MANUALS AND INSTRUCTIONS AND KEEP IN A SAFE PLACE.**



2. ROTATING BLADE

- Keep both hands on handles when blade is rotating.
- Keep feet and hands away from cutting area.
- Do not attempt to remove cut debris or hold material to be cut when engine is running or when blade is moving.
- Make sure spark plug wire is disconnected when clearing jammed material from blade or cutter head.

CAUTION - Blade coasts after machine is turned off.



3. DO NOT USE MACHINE ON GRAVELED SURFACES. Thrown objects can cause serious injuries and/or property damage.

4. KEEP OPERATING AREA CLEAR - Keep the area of operation clear of all persons and pets.

5. USE EDGER PROPERLY - Use only for edging the type of shrub, growth and the like described in the operating instructions. Do not abuse machine. Do not use in rain or wet locations.

6. DON'T OVERREACH OR STAND ON UNSTABLE SUPPORT - Keep good footing and balance at all times.



7. NEVER DIRECT DISCHARGE OF MATERIAL TOWARD BYSTANDERS OR ALLOW ANYONE NEAR THE AREA OF OPERATION.

Use care in directing discharge to avoid glass enclosures, automobiles, and the like.



8. OBJECTS STRUCK BY THE BLADE CAN CAUSE SEVERE INJURIES TO PERSON.

The lawn should always be carefully examined and cleared of all objects prior to use.

9. STAY ALERT FOR UNEVEN SIDEWALKS, HOLES IN TERRAIN OR OTHER SIMILAR CONDITIONS.

Always push slowly over rough ground.

10. NEVER OPERATE MACHINE WITHOUT GOOD VISIBILITY OR LIGHT.

11. STAY ALERT - Watch what you are doing - use common sense. Do not operate product when fatigued or under the influence of alcohol or drugs.

12. DRESS PROPERLY - Wear safety glasses or goggles. Do not wear loose clothing or jewelry. They can be caught in moving parts. Use of sturdy gloves and safety footwear is recommended. Always wear pants that cover legs.

13. DISCONNECT (UNPLUG) SPARK PLUG LEAD WIRE:

- When not in use.
- Before servicing, cleaning and the like.
- Before changing blade, belt, etc.

14. MAINTAIN PRODUCT WITH CARE -

Follow maintenance instructions given in Manuals. To reduce the risk of fire, do not allow excessive grass, leaves, or grease to accumulate on the machine.



The engine exhaust from this product contains chemicals known to the State of California to cause cancer, birth defects or other reproductive harm.

15. STORE MACHINE INDOORS - When not in use, store indoors in a dry place, locked or otherwise inaccessible to children.

16. DO NOT ATTEMPT TO REPAIR MACHINE - Have repairs made by qualified dealer or repairman. Use only original Little Wonder replacement parts.

17. HANDLE GAS WITH CARE; IT IS HIGHLY FLAMMABLE.

- a) Use a gas container acceptable for the purpose and do not store gas in the house.
- b) Never add gas to a running or hot engine.
- c) Fill gas tank outdoors with extreme care. Never fill gas tank indoors.
- d) Replace gas cap securely.
- e) If gas is spilled, move Edger and gas container from area and do not create a source of ignition.



18. To reduce the risk of fire, replace gasoline cap securely.

19. START THE ENGINE CAREFULLY. Keep hands, feet, clothing and the like well away from blade and moving parts.

20. NEVER ATTEMPT TO MAKE ADJUSTMENTS while the engine is running, except to the carburetor.



21. DO NOT RUN THE ENGINE INDOORS - Exhaust flames are dangerous. The engine exhaust from this product contains chemicals known to the State of California to cause cancer, birth defects or other reproductive harm.

22. IF BLADE STRIKES A FOREIGN OBJECT, FOLLOW THESE STEPS:

- a) Stop the engine.
- b) Disconnect the spark plug lead.
- c) Inspect for any damage.
- d) Repair any damage before restarting and operating the machine.

23. DISENGAGE THE BLADE AND/OR STOP THE ENGINE WHEN THE MACHINE IS TRANSPORTED OR NOT IN USE.

24. STOP THE ENGINE WHEN LEAVING THE MACHINE UNATTENDED.

25. WHEN CLEANING, REPAIRING, OR INSPECTING, make certain the blade and all moving parts have stopped. Disconnect the spark plug wire, and keep the wire away from the plug so that unintentional starting does not occur.

26. NEVER OPERATE THE MACHINE without guards or other productive devices in place. Before each use, check all fasteners and safety devices for proper function.

27. MULTIPLE OPERATORS - Keep a safe distance between two or more operators when working together simultaneously.

28. BE SURE MACHINE IS FULLY ASSEMBLED - Never operate without all guards and deflectors in place. Ensure that all nuts, bolts, screws are installed and properly tightened. Check pulley set screws and all fasteners for tightness and lubricate cutter head shaft, key, keyway and bushings with light oil prior to each use.

29. ALWAYS KEEP THE THROTTLE IN THE "STOP" POSITION WHEN NOT IN USE.

30. LABELS SHOULD BE INSPECTED BEFORE EACH USE. Replace damaged labels immediately. See Safety Decal Identification on page 4.

SAFETY DECAL IDENTIFICATION

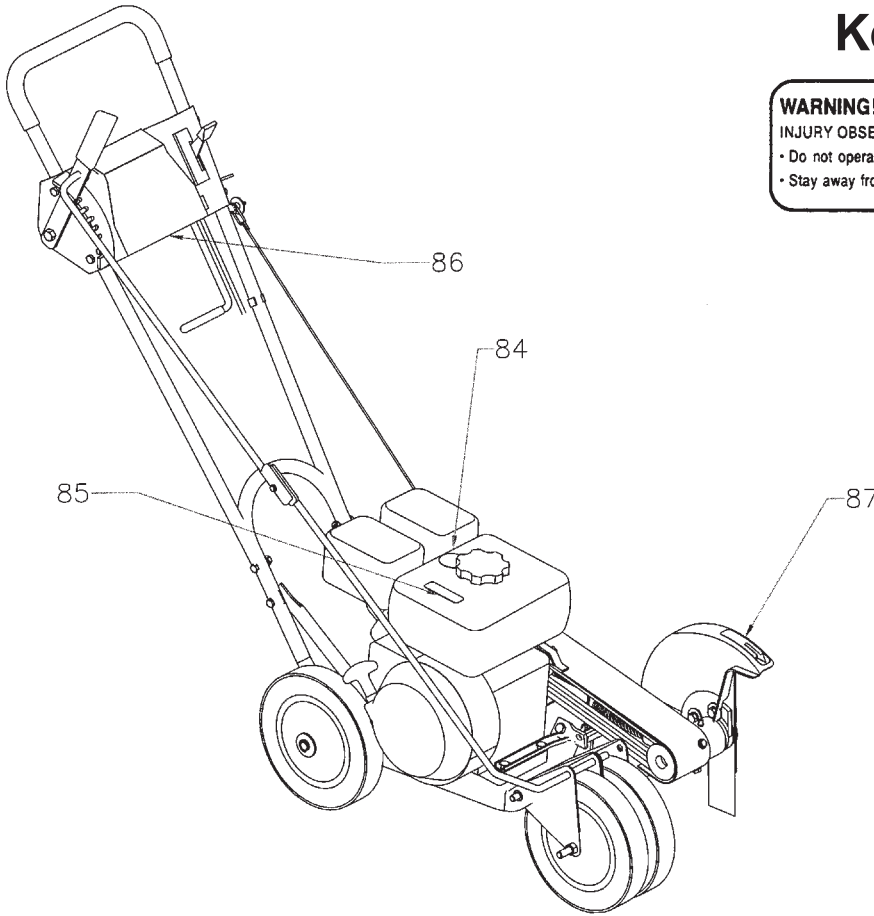

Key #87 P/N 210

WARNING! TO GUARD AGAINST INJURY OBSERVE THE FOLLOWING:

- Do not operate without guards in place
- Stay away from this covering - rotating blades

DIRECTION OF ROTATION



Key #84 P/N 4036



Key #85 P/N 211

CAUTION

- Use eye protection, rotating blade may throw objects.
- Read operator's manual before use.
- To reduce risk of fire, replace gasoline cap securely.
- Do not operate without guards in place.

Key #86 P/N 272

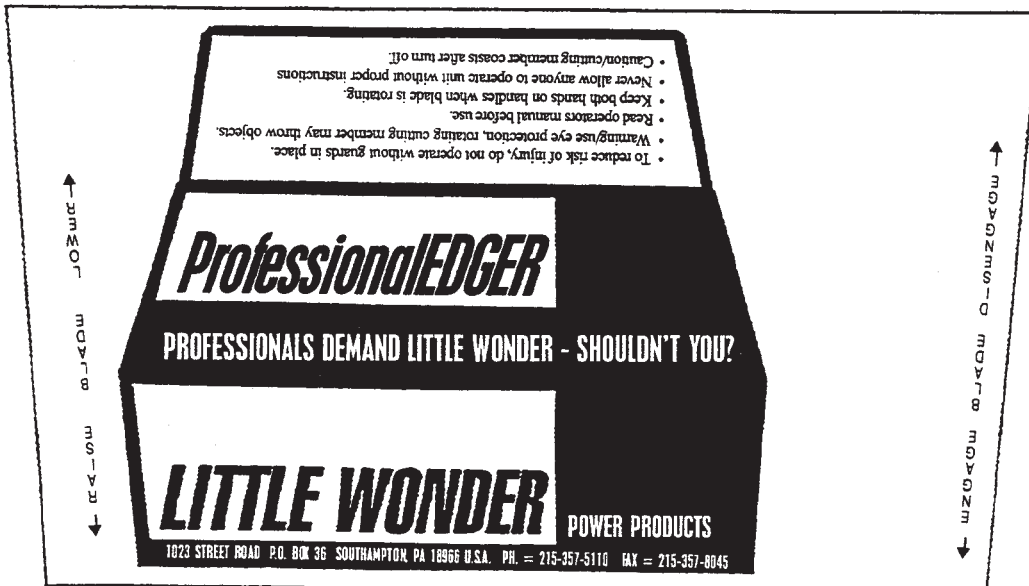

PARTS LIST

ITEM	PART NO.	DESCRIPTION	QTY	ITEM	PART NO.	DESCRIPTION	QTY
1	162B	Hex Head Cap Screw 1/4-20 X 1/2	2	46	184	Axle	1
2	118	Set Screw 5/16-18 X 3/8	4	47	-----		
3	124	Bearing	2	48	185	Clevis Pin	1
4	129D	Lock Washer 5/16	5	49	4163306	Bolt, Eye End 1/4-20x1.40	1
5	131A	Cutter Head Shaft	1	50	102B	Hex Nut 3/8-16	2
6	128	Blade Washer	2	51	113	Hex Head Cap Screw 5/16-18 X1 1/2	4
7	121	Woodruff Key #606	1	52	194	Hex Head Cap Screw 3/8-16x5 1/2	1
8	132	Tension Pin 1/4 X 1 1/4	1	53	102C	Sleeve	2
9	100-C	Deck Bracket	1	54	100D	Deck Bracket Support	1
10	220	Pulley Cutter Head	1	55	4163572	Adjusting Rod Lower	1
11	472	Lock Nut 1/4-20	16	56	171	Clevis Pin	1
12	-----			57	100	Deck	1
13	134	Spring	1	58	193	Front Wheel Bracket	1
14	181	Cutter Blade Shaft	1	59	108	Wheel Housing	2
15	126	Cutter Head	1	60	170	Clevis Pin	1
16	130	Nut 1/2-20	1	61	266	Handle Support - LH	1
17	129	Blade	1	62	106	Wheel	3
18	138	Key Head Shaft	1	63	410	Hex Head Cap Screw 1/4-20 X 5/8	1
19	192	Guide Plate	1	64	155	Adjusting Rod Upper	1
20	114B	Flange Nut 5/16-18	10	65	980	Hex Head Cap Screw 3/8-16 X 2	1
21	122	Retaining Ring	1	66	218	Spring	1
22	129C	Hex Head Cap Screw 5/16-18 X 3/4	8	67	165A	Grip	1
23	129B	Blade Guard	1	68	227	Grip - Lever	1
24	191	Guide Bracket	1	69	226	Handle Brace	1
25	163	Washer - 3/8 ID	5	70	8-18	Grip Ring	1
26	177	V Belt	2	71	167-2	Belt Slackener Lever	1
27	195	Belt Guard	1	72	198	Draw Rod	1
28	140	Hex Head Cap Screw 1/4 - 20 x 3/8	2	73	146B	Throttle Clip	1
29	196	Hex Head Cap Screw 5/16-24 x 1 1/4	1	74	271	Throttle Adjust Assembly	1
30	197	Jam Nut 5/16-24	1	75	167A	Speed Nut	1
31	251	Pulley - Engine	1	76	228	Lever	1
32	262	Engine-4hP Honda	1	77	142-2	Handle Upper	1
		(Used on 6232-00-01 model only)		78	219	Bracket	1
		280 Engine-127cc B&S		79	236	Grip - Handle	2
		(Used on 6033-00-01 model only)		80	-----		
33	212	Bracket	1	81	144-1	Hex Head Cap Screw 1/4-20X1 1/4	12
34	213	Hex Head Cap Screw 5/16 - 24 X 3/4	3	82	208	Hex Head Cap Screw #10-32 X3/4	1
35	253	Adapter Plate	1	83	973	Lock Nut #10-32	1
36	117	Key, Pulley - 3/16" square	1	84	4036	Hearing Protection Label	1
37	4163308	Formed Rod .19 x 2.28	1	85	211	Caution Label	1
38	209	Mud Flap	1	86	272	Brace Label	1
39	176	Washer 1/2 ID	8	87	210	Rotation Caution Label 1	
40	156	Cotter Pin	2	88	264	Muffler, Exhaust Deflector	1
41	267	Handle Support - RH	2	89	265	Muffler, Exhaust Deflector Screw	2
42	103	Retaining Ring	2	90	107	Offset Wheel	1
43	169	Link Belt Slackener	1	91	175B	Nut, 1/4-20	1
44	141-2	Handle-Lower	1				
45	-----						

ASSEMBLY INSTRUCTIONS

Your Little Wonder Pro Edger requires a minimal amount of assembly prior to use.

1. Remove two nuts & bolts (key #'s 11 & 81), holding handle supports (key #'s 41 & 61) to lower handle (key #44).
2. Align upper handle (key #77) with lower handle (key #44) and replace the two nuts and bolts that were removed in step one.
3. Use two bolts & nuts (Key # 80 & 11) in the upper holes of the handles - now tighten all four bolts.
4. Use a #10-32 x 1 1/4 screw and lock nut (key #'s 82 & 83) to connect the upper adjusting rod (key #64) to the lower adjusting rod (key #55).
5. Remove cotter pin and washer (key #'s 40 & 25) from belt slackener lever (key #71) and place elongated loop of the draw bar (key #72) onto the belt slackener lever. Place washer back on and install cotter pin bending the legs once it is in place.
6. Remove the cotter pin (key #40) from the clevis pin (key #60) and slide the clevis pin out of its hole. Place the round hole of the draw bar (key #72) between the two holes of the link belt slackener (key #43) and slide clevis pin back in place.
7. Replace cotter pin and bend the legs.
8. Rotate the mud flap (key #38) out from under the machine so that it is as far forward as possible without touching the blade while the edger is in its lowest position and the rubber flap is bent forward. Tighten from underneath.
9. Place blade guard (key # 23) on cutter head assembly (key # 15) as shown in fig. 2, and install 5/16 washers, lock washers, and screws (key #'s 25, 4 & 22). **NOTE:** The blade guard has slotted holes for adjusting. Location of the blade guard should be adjusted so that the bottom of the guard just clears the ground while edging.
10. Remove 1/2 -20 nut (key # 16) and one washer (key # 6), place blade (key # 17) on shaft, then reinstall washer and nut.

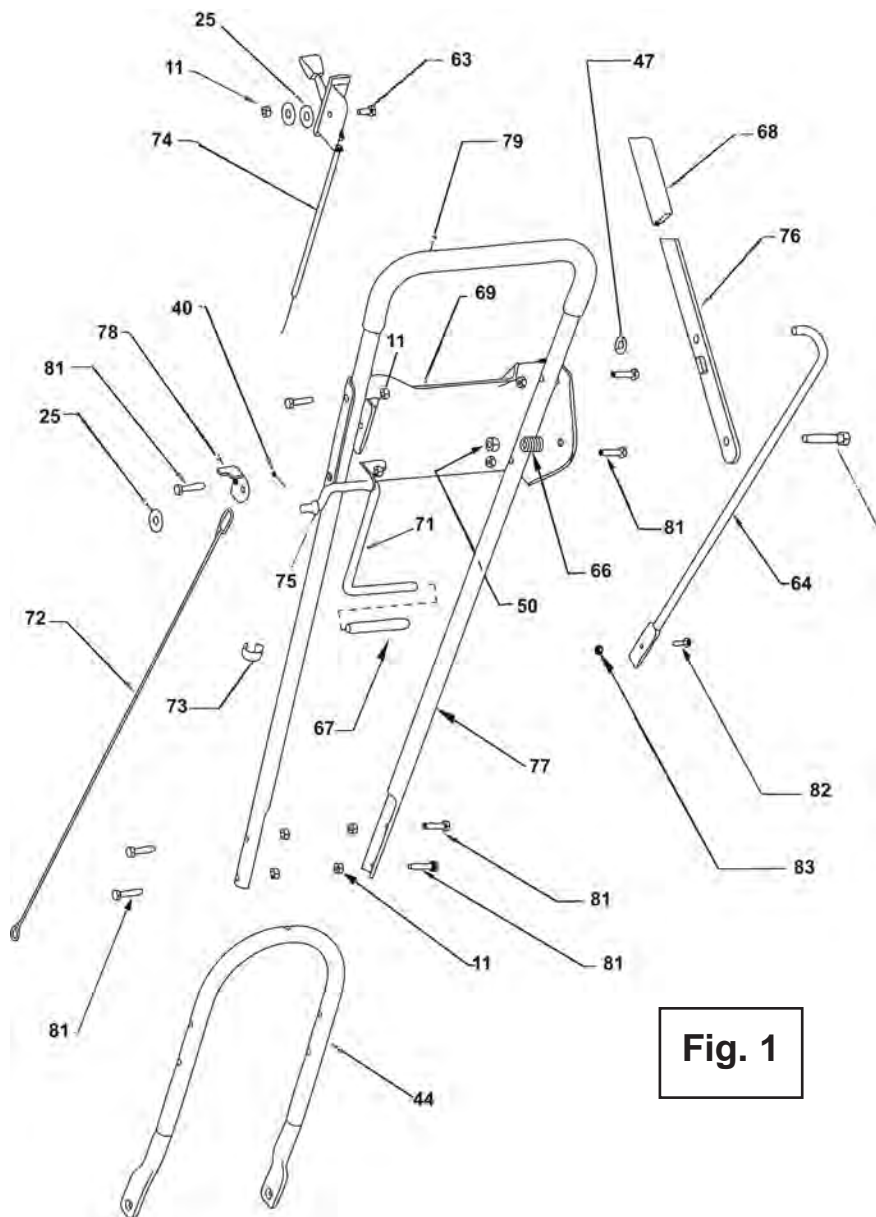

Fig. 1

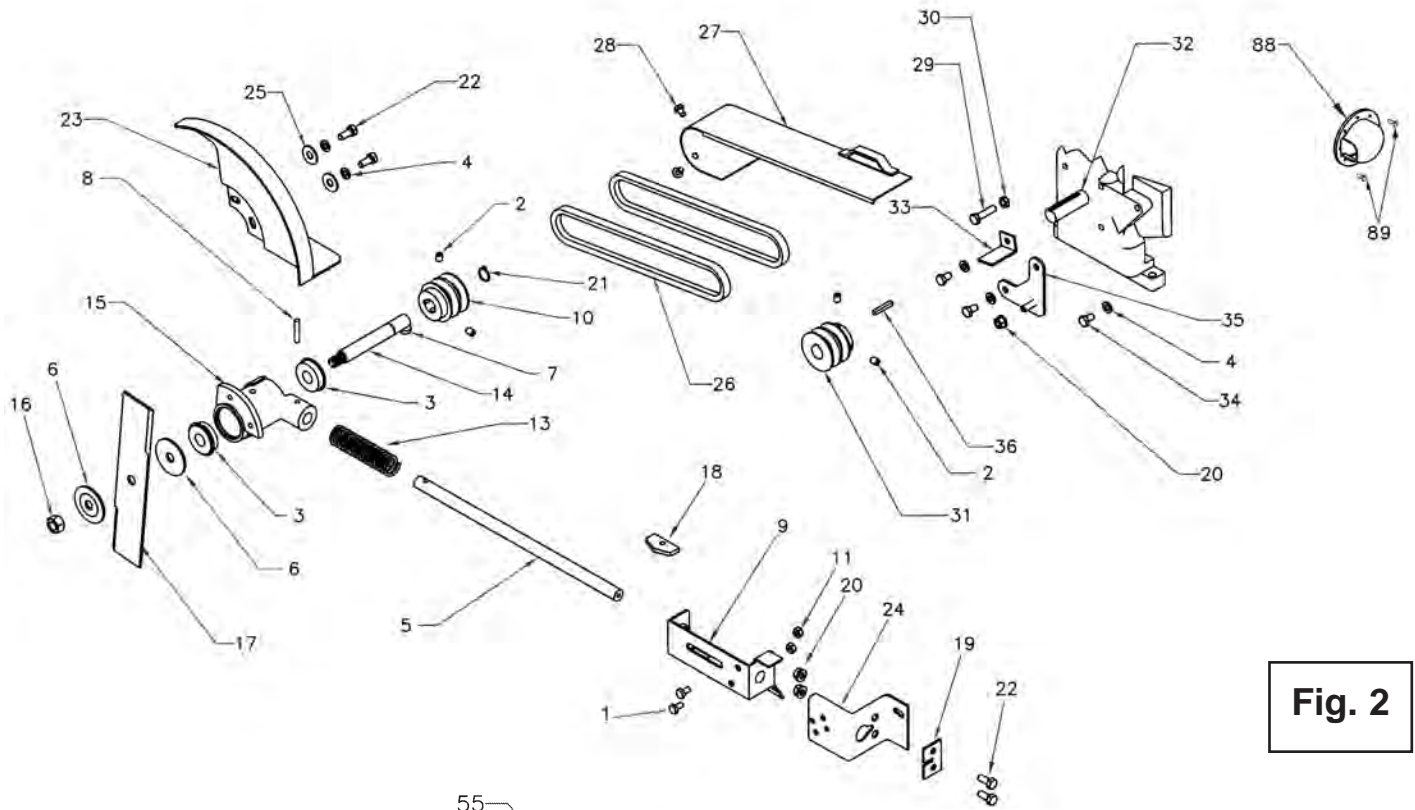

Fig. 2

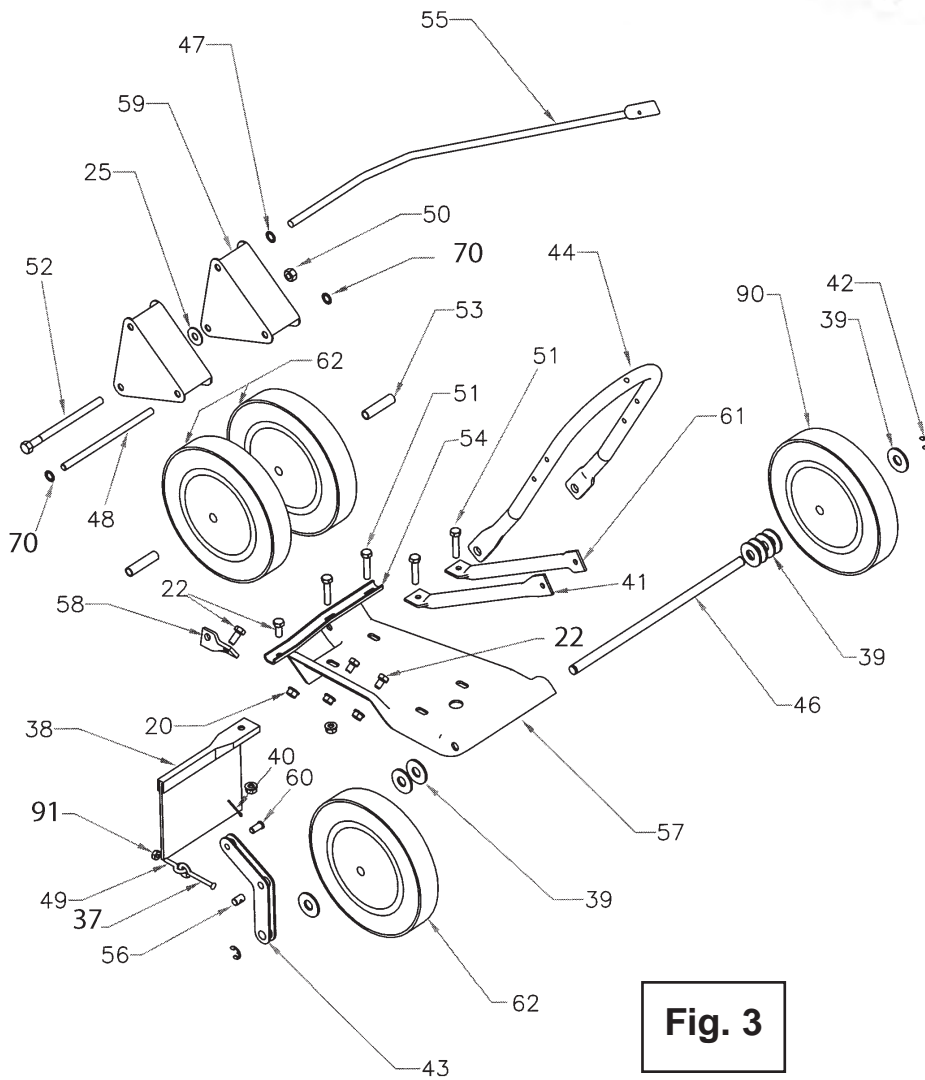

Fig. 3

THROTTLE INSTALLATION INSTRUCTIONS

1. Remove the air filter cover from the engine.
2. Use a 10mm socket to loosen the throttle lever pivot nut.
3. Move the remote throttle lever all the way to slow (turtle) position. Move it 1/16" - 1/8" back towards the fast (rabbit) position.
4. Move the engine throttle lever to the slow position (push throttle lever to the front of the edger).
5. Remove the throttle cable retaining clamp and screw from the engine.
6. Insert the end of the throttle cable into the hole on the engine throttle lever.
7. Place the cable-retaining clamp over the cable, insert the screw in and pull back and tighten.
8. Replace the air filter cover.
9. The remote throttle lever should move from slow to fast and be approximately centered in its slot.
10. If the throttle feels tight, loosen the engine throttle lever pivot nut.
11. If the throttle does not stay where it is placed, tighten the remote throttle lever pivot nut (key # 63).

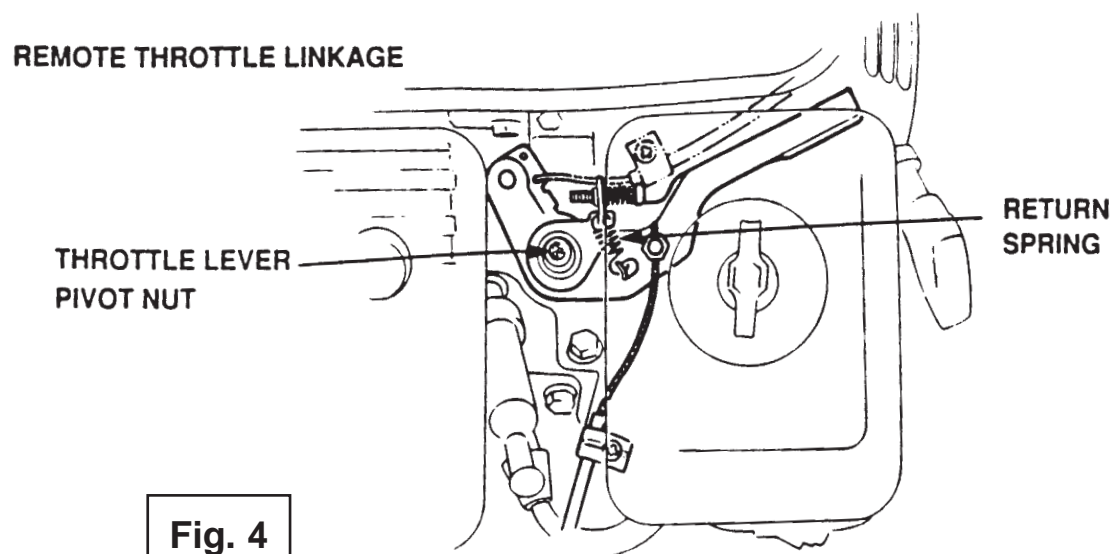

Fig. 4

OPERATING INSTRUCTIONS

A. BEFORE STARTING

1. Place Edger on level surface; be sure blade is not obstructed and the area is clear and free of bystanders.
2. Check oil level, and be sure crankcase is filled with oil.
3. Fill gas tank with fresh gas. Do not mix gas with oil.

NOTE: Refer to the engine Operating and Maintenance Instructions for recommended grades of oil and gas.

4. For easier starting, remove belt tension by pulling up the belt slackener lever (P/N 167-2).

B. STARTING PROCEDURE

1. For easier starting, remove belt tension by pulling up the belt slackener lever (P/N 167-2).
2. Prior to starting the engine, secure and hold the edger handle with your left hand.
3. Refer to your Engine Operator/Owner Manual for Engine Starting Instructions.
4. Once the engine starts, set the throttle control lever to desired speed.

NOTE: A warm engine requires less choking than a cold engine.

C. STOP PROCEDURE

1. Pull throttle lever towards you to STOP position.
2. Turn engine switch to OFF position.



D. CAUTION

1. Do not change the engine governor settings or overspeed the engine.
2. If the product vibrates abnormally, immediately stop the engine and check for the cause. Vibration is generally a warning sign of trouble.
3. Stop the engine whenever you leave the operating position; disconnect the spark plug lead wire before unclogging the unit, when making a repair, adjustment, inspection or the like.
4. Operate machine from position where guards block the line of sight to the cutting member.

⚠ WARNING ⚠ DANGER ⚠

ALL LITTLE WONDER EDGERS ARE SHIPPED WITHOUT OIL. WHEN FILLING OIL- USE SAE 30 OIL. REFER TO ENGINE MANUFACTURERS INSTRUCTION MANUAL FOR PROPER ENGINE OPERATION INSTRUCTIONS.

E. OPERATING

1. Eye protection must be worn at all times. Use common sense and exercise caution at all times when operating your Edger.
2. Operate in a safe manner. When edging, the potential exists for thrown objects which can cause injury (i.e.) from rocks, cement, pieces of steel, glass, etc. These obstructions should be avoided at all times.
3. Never leave the machine when the engine is running, particularly on hills where the unit might roll.
4. Setting depth of blade. (1) Place left hand on upper handle. (2) Grasp lever, P/N 228, with right hand and pull to the right, which disengages lever from ratchet segment on handle. Move lever forward or backward along ratchet segment and insert key on lever into notch on ratchet at the desired depth. Moving lever forward decreases depth of cut, moving lever backward increases depth of cut.
6. Engine speed - The engine speed should be kept to the minimum consistent with the job at hand. Speeds higher than necessary will only cause undue wear and tear. A speed half-way between "fast" and "slow" is normally adequate. Tougher jobs may require higher speeds.
7. Little Wonder Edgers provide the finishing touch. They edge at any angle along flower beds, terraces, sidewalks and curbs. They trim along buildings, trees, walks, marker hedges and fences with ease and reliability.
8. Edging - The blade should be perpendicular to the ground or sidewalk. The cutting depth should be sufficient to cut away the root system, usually 1" to 1 1/2" deep. Along flush sidewalks or driveways, it is easier to place the wheels on the sidewalk or driveway rather than the grass. The hardened tool steel blade, P/N 129, becomes its own guide if it is permitted to rub against the side or edge of the sidewalk or driveway. Angles other than vertical may be desirable when edging flower beds, walls, posts, etc. When edging along a curve, the rear wheels should be held off the ground so the machine may be maneuvered "wheelbarrow fashion."

USER MAINTENANCE INSTRUCTIONS

1. Keep all nuts, bolts and screws tight.
2. Never store the machine filled with fuel inside a building or in a confined space where fumes may be susceptible to sparks or an open flame.
3. Refer to the instructions manual for important details if the product is to be stored for an extended period of time.
4. Check the tightness of the blade nut prior to each use.
5. Prior to each use, lubricate cutter head shaft (P/N 131A), cutter head bracket (P/N I00C), and key (P/N 138) at slip rotation points every 8 hours
6. Prior to each use, check to see that set screws on pulley are tight, and guards are in place.

NOTE: The belt guard is an important safety feature and is vital to the proper operation of the edger.



Loose set screws can cause damage to shaft and pulley. Improper maintenance will void warranty.

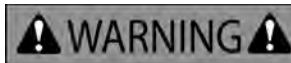

WARNING: The engine on your Pro Honda Edger is not equipped with a spark arrester and if machine is to be used on any forest-covered, brush-covered, or grass-covered unimproved land, before using on such land a spark arrester must be added to the muffler. The arrester must be maintained in effective working order by the operator. In the State of California, the above is required by law (Section 4442 of the California Public Resources Code). Other states may have similar laws. Federal laws apply on federal lands. See your Authorized Honda Service Center for spark arrester muffler options.

NOTE: The belt guard is vital to the proper operation of the edger. The belt guard is not just a safety feature!

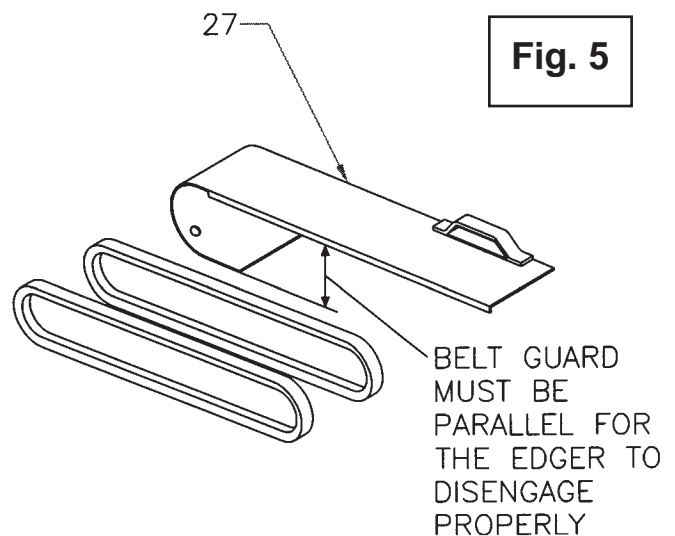

TROUBLESHOOTING GUIDE

PROBLEM	POSSIBLE CAUSE	CORRECTIVE ACTION
A. Engine will not start	<ol style="list-style-type: none"> 1. Out of gasoline. 2. Spark plug lead wire loose or disconnected. 3. Defective spark plug. 4. Throttle control lever not in proper position. 5. Engine flooded or flooding. 6. Stale or contaminated gasoline. 7. Engine switch off. 8. Oil level low. 	<ol style="list-style-type: none"> 1. Fill gasoline tank. 2. Reconnect spark plug lead wire. 3. Replace spark plug. 4. Move throttle control lever to start position. 5. Start engine with choke fully open. 6. Drain, clean tank and system and refill with fresh gasoline. 7. Turn engine switch to ON position. 8. Fill crankcase to proper oil level.
B. Loss of power, hard starting.	<ol style="list-style-type: none"> 1. Spark plug lead wire loose. 2. Defective spark plug. 3. Carburetor out of adjustment. 4. Air cleaner dirty. 5. Air vents clogged or plugged. 	<ol style="list-style-type: none"> 1. Tighten spark plug lead wire. 2. Replace spark plug. 3. Properly adjust carburetor. 4. Clean and service air cleaner. (See the engine Operation and Maintenance illustrations.) 5. Clean vent in gasoline tank cap and carburetor.
C. Engine will not idle properly.	<ol style="list-style-type: none"> 1. Idle speed too slow. 2. Spark plug gap incorrect. 3. Air cleaner dirty. 	<ol style="list-style-type: none"> 1. Adjust carburetor idle speed or idle mixture. 2. Set spark plug gap; see your Engine Manual 3. Clean and service air cleaner. (See the engine Operation and Maintenance illustrations.)
D. Engine runs hot or overheats.	<ol style="list-style-type: none"> 1. Oil level low. 2. Engine cooling fins or baffles clogged with dirt and debris. 3. Carburetor out of adjustment. 	<ol style="list-style-type: none"> 1. Fill crankcase to proper oil level. 2. Clean and remove obstructions. 3. Readjust carburetor.
E. Control mechanisms for depth of blade will not function.	<ol style="list-style-type: none"> 1. Parts bent, distorted, worn out or missing. 	<ol style="list-style-type: none"> 1. Inspect control mechanism and repair or replace damaged, worn out, or missing components.

LIMITED SERVICE AND WARRANTY POLICY

All Little Wonder products are guaranteed against defects in workmanship for a period of ONE YEAR FROM DATE OF PURCHASE when used for RESIDENTIAL SERVICE, NINETY DAYS FROM DATE OF PURCHASE FOR COMMERCIAL SERVICE. Any Little Wonder products or parts found to be defective within the warranty period are to be returned to an authorized Little Wonder dealer.

Transportation charges on parts and units submitted for replacement under this warranty must be borne by purchaser.

Engines for gas powered edgers are warranted separately by the engine manufacturer. Therefore, there are no warranties made, express or implied, for engines for gas powered edgers by Little Wonder.

THIS WARRANTY shall not be effective if the product has been the subject of misuse, negligence or accident or if the product has been repaired or altered outside of our Southampton factory in any respect which affects its condition or operation.

Little Wonder shall not be liable for any special indirect or consequential damages arising from defective equipment. Any implied warranty, including merchantability or fitness for a particular use, shall not extend beyond the written period.

THIS WARRANTY shall only be effective if enclosed warranty card is properly filled out and returned to Little Wonder, Division of Schiller-Pfeiffer, Inc., 1028 Street Road, Southampton, PA 18966 at time of purchase.

268 10/2010

LITTLE WONDER®

1028 STREET ROAD, P.O. BOX 38, SOUTHAMPTON, PA 18966
PHONE: 215-357-5110 • FAX: 215-357-8045

Professionals Demand Little Wonder. Shouldn't You?